

Litium soldering training kit for surface mount components

General

Litium soldering training kit is designed especially for learning surface mount soldering. It has all together 64 components to solder. It is well suited for both hand soldering and automated soldering exercises.

Soldering pads on the board are coated with lead-free HASL coating that makes it possible to make good lead-free solder joints.

Before working with the components you should have some basic knowledge on ESD protection.

Avoid touching the components and soldering pads. Wipe the surfaces of the board with suitable cleaning solution if necessary.

Components

First make yourself familiar with the components included. Make sure that you identify each component before you solder them. From the table below you can find out the quantity of each component type, label, type, packaging type, marking on the component and info of the possible polarity or mounting direction of the component. A component with polarity is one that must be mounted the right way around on the board.

Part list

Part#	Amount	Label	Component type	Packaging	Markings	Polarity / Mounting direction matters
1	3	U1-U3	CMOS IC 4017	SO-16	4017	Yes
2	1	U4	CMOS IC 4093	SO-14	4093	Yes
3	12	D1-D12	Double diode BAV70	SOT-23	A4t (JJ)	Yes
4	18	LD1-LD18	LED EL15-21	1206	-	Yes
5	1	LD19	LED EL42-21	-	-	Yes
6	3	R1-R3	Resistor 1 M Ω	0805	1003	No
7	19	R4-R22	Resistor 470 Ω	0805	4700	No
8	7	C1-C7	Capacitor 100 nF	1206	-	No

Integrated Circuits

On picture 1. you can see the ICs used in the project. The IC on the left is in a SO-16 packaging and the one on the right is in a SO-14 packaging. Abbreviation SO comes from the words **Small Outline Package** and the number behind tells how many pins the component has.

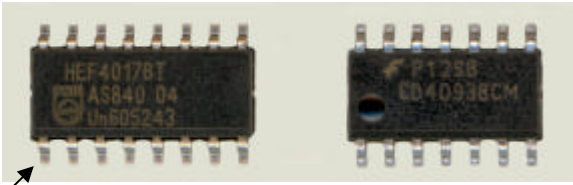

Picture 1. Integrated Circuits (ICs)

All ICs are with polarity so they must be mounted the right way around on the board. On picture 1. the ICs are pictured so that the printings on them are readable and text is the right way up. In this position pin number 1 is at the lower left corner.

Pin number one is not marked in any way on the IC on the left. On the IC on the right there is a small round indentation that is commonly used to mark pin number 1.

Pin number 1 is marked with a dot on the silk screen printing of the printed circuit board.

In this case only the numbers 4017 and 4093 are relevant. Letters before and after these numbers may vary and be different from the ones on picture 1.

Diodes

The double diode BAV70 used in the project is shown on picture 2. Its packaging type is SOT-23. Also diodes are with polarity but as SOT-23 packaging has three pins it can't be placed the wrong way around on the board.



Picture 2. Double diode

The symbol and pin configuration of BAV70 is shown on picture 3. Any other double diode can be used as long as the pin configuration is the same as displayed on picture 3.

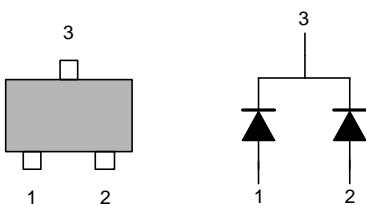

Picture 3. BAV70 diode pin configuration

The labels printed on surface mount diodes and other semiconductors are different from the through solder ones. The identification is usually a two or three character code. The code of the same component varies with the manufacturer. For example the code for BAV70 can be A4 (Fairchild), A4t, A4p, A4W (Philips) or JJ (Vishay).

LEDs

Show in picture 4 are the LEDs used. LEDs LD1-LD18 (18 pcs) are shown on the left. The LED at the centre of the board is show on the right.

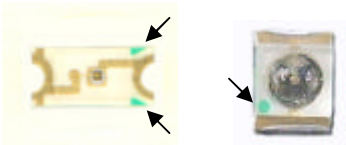

Picture 4. LEDs

LEDs are components with polarity so they must be mounted the right way around on the board. On the left you can see how the cathode of the LED is marked with green dots on two sides of the LED.

The LED on the right has its cathode marked also with a green dot at the lower left corner.

Resistors and capacitors

Resistors and capacitors used are rectangular chip components and are shown on picture 5.



Picture 5. Chip resistor and chip capacitor

Chip components' size marking 0805 or 1206 tells the mechanical size of the component in mills. First two numbers gives the length in mills and last two tells the width in mills.

Resistors used in this project are size **0805**.

08 = 80 / 1000 inch = 80 mils ~ 2 mm
05 = 50 / 1000 inch = 50 mils ~ 1,25 mm

Capacitors used in this project are size **1206**.

12 = 120 / 1000 inch = 120 mils ~ 3,2 mm
06 = 60 / 1000 inch = 60 mils ~ 1,6 mm

Resistors of size 0805 are intentionally selected for this project to distinguish them from capacitors (1206), so you can identify resistors by their smaller size.

Two different resistor values are used. The exact values of either are not critical. Resistors supplied may have a slightly different resistance value than defined.

The recommended value of resistors R1, R2 and R3 is 470 k Ω to 1 M Ω . The value affects the blinking frequency of the LEDs. You can change the values of these resistors if you want to have the speed of different ellipses to be different on the three ellipses.

The value of other resistors R4-R22 (19 pcs) influences the brightness of the LEDs and current consumption of the device. The value of these resistors could be between 220 Ω and 1 k Ω . These are also dependant of the supply voltage. The power supply voltage may be from 5 V to 15 V. The greater the voltage is the greater the resistance of resistors R4-R21 should be.

The resistance value of chip resistors is printed on the upper side with three or four numbers. When the value is given with three numbers the first two numbers are the value and the third one is the multiplier. Equally, when the value is given with four numbers the first three numbers are the value and the fourth one is the multiplier.

Examples:

$$\begin{aligned} 3480 &= 348 \Omega * 10^0 = 348 \Omega \\ 471 &= 47 \Omega * 10^1 = 470 \Omega \\ 8203 &= 820 \Omega * 10^3 = 820\,000 \Omega = 820 \text{ k}\Omega \\ 105 &= 10 \Omega * 10^5 = 1\,000\,000 \Omega = 1 \text{ M}\Omega \end{aligned}$$

All the capacitors used on the device are similar (100 nF). The capacitance value of chip capacitors is usually not printed on the component. Capacitors C1-C3 are the capacitors in the three oscillators that sets the frequency of the LED blinking. By changing the values of these capacitors you can change the frequencies to be different from each other and have the three ellipses to run with different speeds. The greater the capacitance is the slower the LEDs will 'run'. Other capacitors C4-C7 are filter capacitors for the power supply and their values can be from nF to 1 μ F.

Printed Circuit Board

Litium soldering training kit for surface mount components has a double sided PCB. Components will be mounted on both sides of the board.

Rotate the board so that the printed text and the component labels are the right way up. Now the side annotation and alignment marks needed by automated assembly machines are located at the lower right corner. The sides are named **Top** and **Bottom**.

All LEDs are mounted on the bottom side and all other components are mounted on the top side.

Production technique will decide which side to assemble first. Assemble and solder first the side with fewer or lighter parts if reflow oven is used. Reflow oven heats the board from the top so when the opposite side is soldered the parts already assembled should stay in place by themselves.

If you want to practice hand soldering with the board it is advisable to solder the top side first in a Reflow oven and after that solder the bottom side with a traditional soldering iron and solder or with a hot air soldering station and solder paste. You can also practice gluing the components in place with the Litium kit.

Bottom of the board is shown in picture 6. Only the LEDs are mounted on the bottom layer (19 pcs).

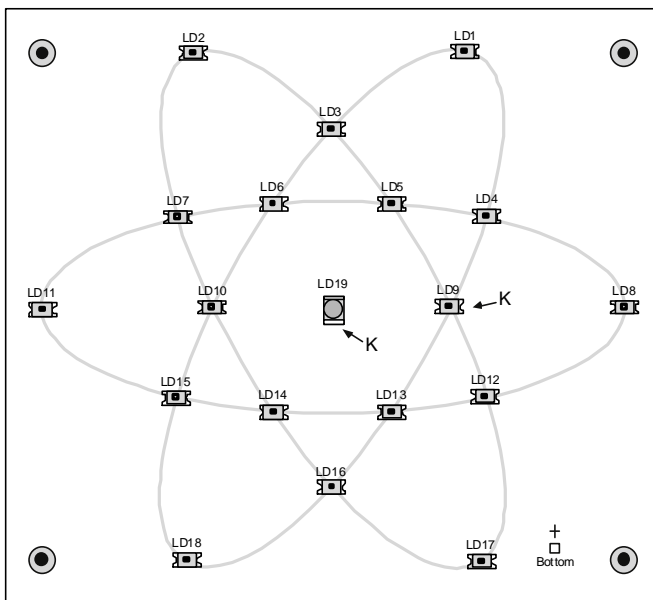

Picture 6. The bottom layer

LEDs LD1-LD17 (17 pcs) are mounted so that their cathodes (the green dots) are pointing to the right. The bigger LED LD18 on the centre is mounted so that its cathode points down. See picture 6.

Top layer is show at picture 7. All other components are mounted on this side. Labels of the components and their positions are show also at picture 7. Component outlines and labels are printed on the printed circuit board.

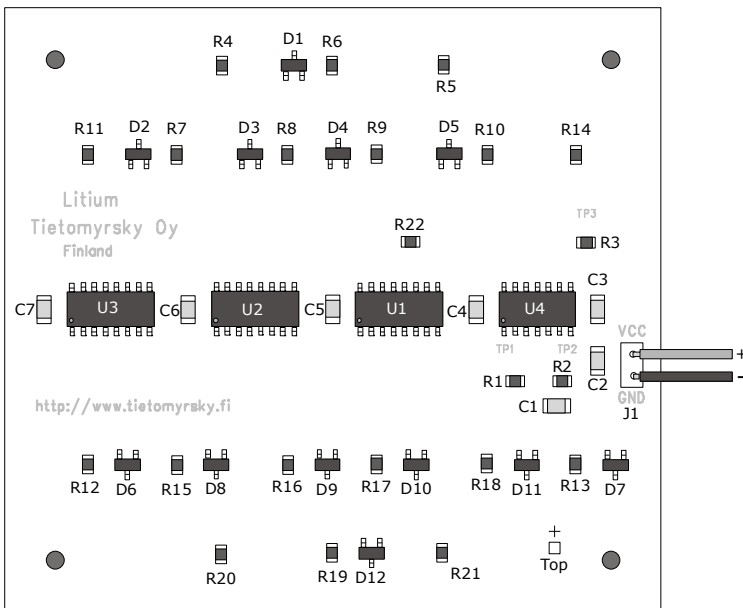

Picture 7. Printed Circuit Board, top layer

Before you start mounting any components it is advisable to take an enlarged photo copy of picture 7 and mark similar components with same values with different color highlighter pens so you can easily locate them when you mount the components. For example, mark resistors R1-R3 with different color than all other resistors because the resistances are not the same. Specifically mark all components that have a certain mounting direction, like diodes, ICs and LEDs.

After all parts are soldered inspect both sides by eye. Make sure that all solder joints look good and that there are no shorts circuits between legs of the ICs.

Solder the battery connector last. The red lead is soldered to connector J1's VCC pad and the black lead to GND pad. Connect a 9 V battery to the battery connector and check that all LEDs on the board blink in their turn. The operating voltage range is from 5 to 15 volts DC.

Schematic diagram

At the end of this document you will find the schematic diagram. It is carefully thought out and specially designed so that it is easy to find out which of the solder joints is at fault when one or more of the LEDs are not lighting up when they should.

There are three independent oscillators which are made of dual-input Schmitt Trigger NANDs (U4-A, U4B and U4-C). The frequency of the oscillators may be changed by altering the values of the resistors and capacitors that form the oscillator. The outputs of the oscillators can be measured from test points TP1, TP2 and TP3.

Oscillators feed counters U1 to U3 (*5-stage Johnson counters*). The outputs of each counter drive the LEDs on the three ellipses. The LEDs at the cross section of ellipses are tied up to two different ellipses. That is why these LEDs are connected with double diodes D1 to D12 to two separate counters' output. For example led LD13 is lit up when either (or both) output of counter U2 pin 9 or counter U1 pin 1 is at high state.

6

5

4

3

2

1

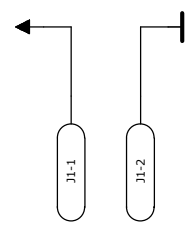
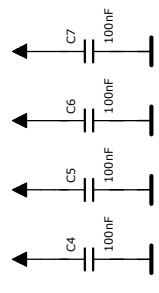
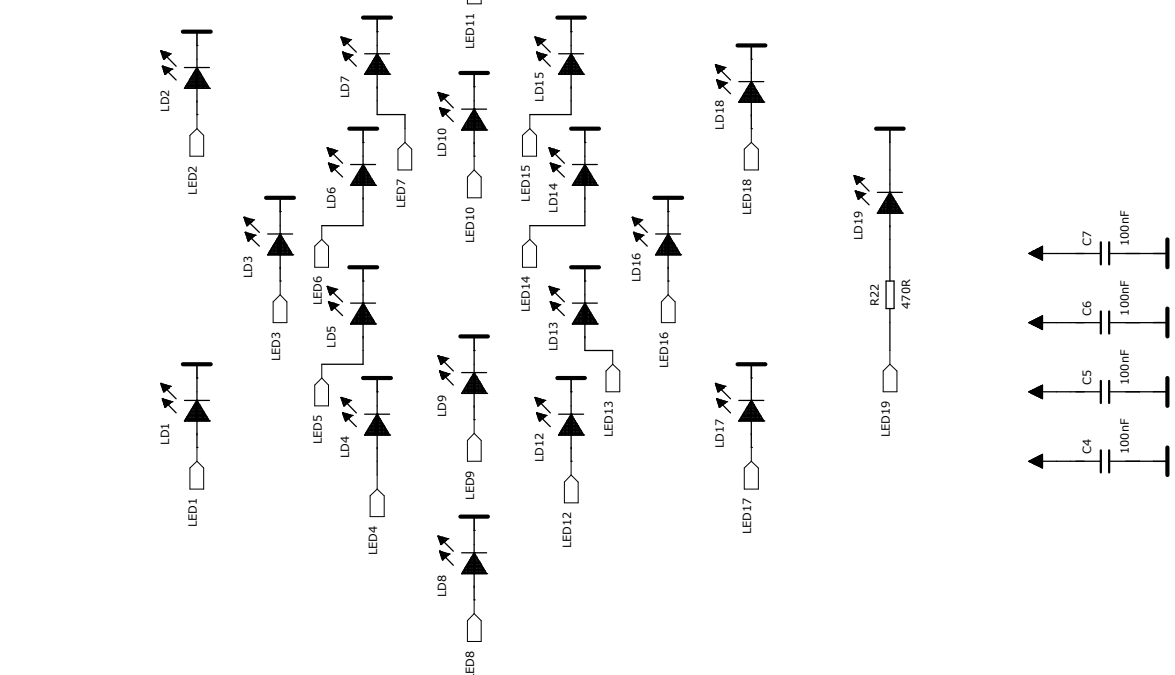
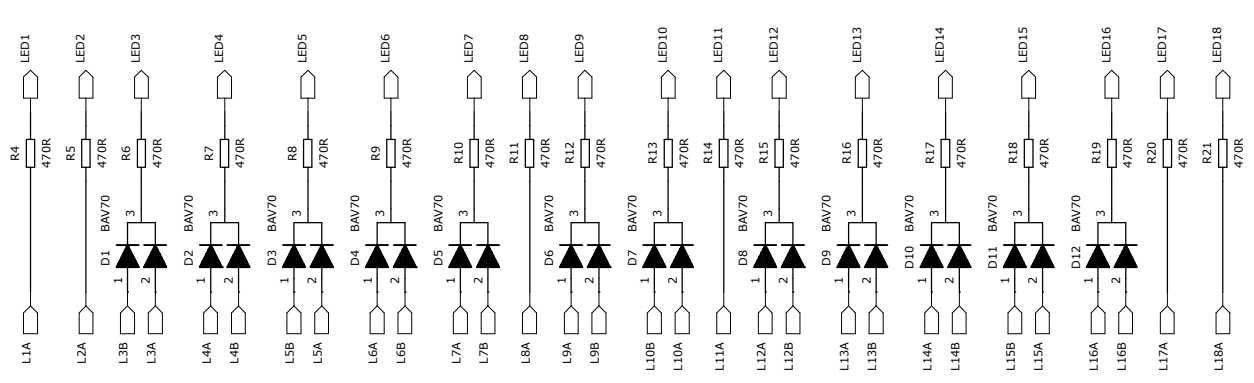
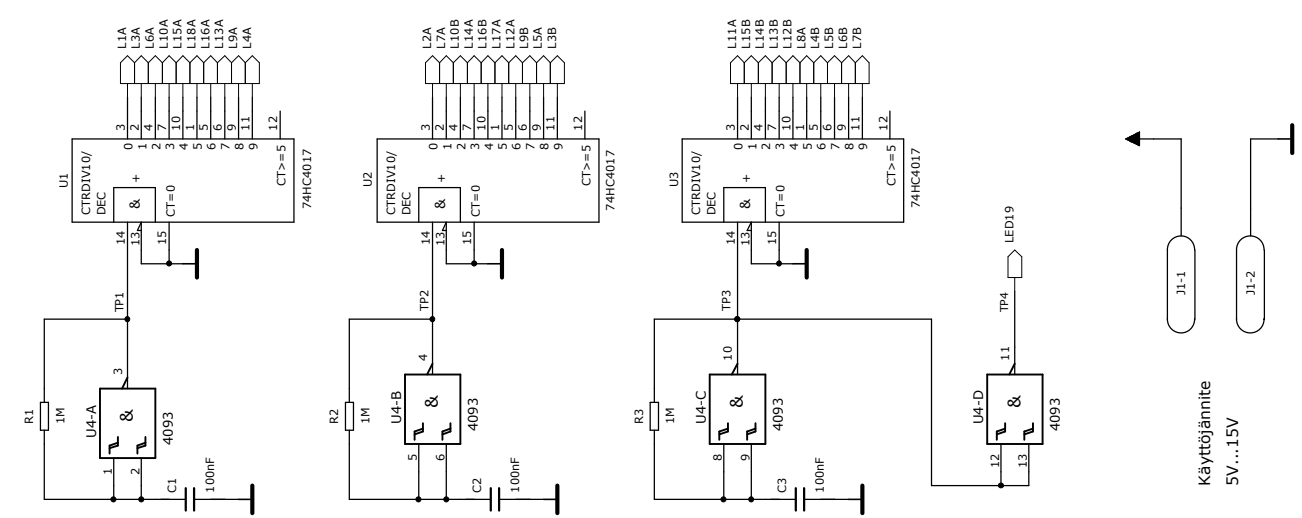

Käyttäjännite
5V...15V

D

C

B

A

D

C

B

A

Tietomyrsky Oy
http://www.tietomyrsky.fi

DRAWN:	JKO	DATED:	050805	TITLE:	
CHECKED:	PKO	DATE:	280806		
				Litium pintaliitoskomponenttien juotosharjoituslevy	